

# Spiral Antenna - Model SCSA-27

Left-circular polarized broadband self-complementary spiral antenna for indoor applications.

## Electrical Specifications

Frequency Range	2 GHz – 27 GHz
VSWR (max.)	< 2:1
Impedance	50 Ω
Connector	SMA female
Gain	-7 to 7 dB
Max RF input Power	1W
Polarization	LHCP or RHCP
Axial ratio	< 2 (2 - 20 GHz) < 3.5 (20 - 27 GHz)
Beamwidth 10dB	90 – 140 degrees
Squint	< 5 degrees



## Physical Specifications

Width	110 mm (4.33 in)
Depth	96 mm (3.78 in)
Height	110 mm (4.33 in)
Weight	560 g (19,75 oz)

Schematic drawing

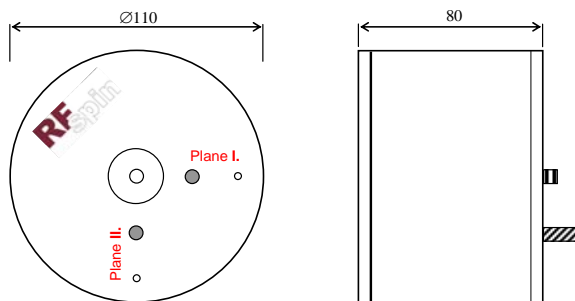

Flange / Adapter

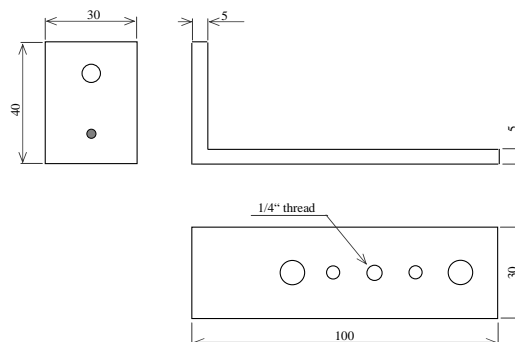

Measured Parameters

